

marathon™ Thomson Power Systems

Series TS 880 • 800 - 4000 Amp
Automatic Transfer Switches



A Regal Brand

REGAL

THOMSON POWER SYSTEMS TS 880 AUTOMATIC TRANSFER SWITCHES OFFER THE FOLLOWING OUTSTANDING FEATURES:

Enclosed Contact Power Switching Units

- **Fully enclosed** silver alloy contacts provide high withstand rating & 100% continuous current rating
- **3 cycle** short circuit current withstand tested
- **Completely separate** utility and generator side power switching units
- **Not damaged if manually switched** while in service
- **Safe manual operation** permits easy operation

Superior Serviceability

- All mechanical and control devices are visible and readily accessible

Control Features

- **TSC 900** microprocessor based controller with comprehensive features
- Isolation plug permits disconnecting control circuits from all power sources

Quality Assurance

- ISO 9001 Registered

Product Data

- Models available from 800 - 4000 Amp continuous
- Available 3 or 4 pole
- All models 50/60Hz rated
- Voltage range 208 - 600
- 3 Phase, 3 or 4 wire systems

Seismic Certification: TS 880 is certified for installation and operation per the following requirements:

- IBC 2006 – Section 13, Occupancy Category IV
- ASCE7-05 Region 3 (minimum SS=342%)
- OSHPD Certified

Safety Standards

- UL 1008
- CSA C22.2 No. 178 Automatic Transfer Switches

GENERAL DESCRIPTION

STANDARD ATS

Thomson Power Systems **TS 880 Standard Automatic Transfer Switches** employ two mechanically interlocked power switching units with a micro-processor based controller to automatically start a generator and transfer system load to a generator supply in the event of a utility supply failure. System load is then automatically retransferred back to the utility supply following restoration of the utility power source to within normal operating limits. All load transfer sequences are "Open Transition" (i.e. "break-before-make") with adjustable neutral position delay unless the Closed Transition option is supplied with the transfer switch.

TS 880 Automatic Transfer Switches are specifically designed and certified to CSA C22.2 No. 178 & UL 1008 Standards.

All **TS 880** transfer switch models have been 3 with-stand current tested in accordance with UL 1008 and CSA178. The standard **TS 880** Automatic Transfer Switch is rated for 100% system load. The **TS 880** design allows optional use

of integral over current trip elements within the power switching units.

The **TS 880** series transfer switches use a type **TSC 900 microprocessor based controller**. All necessary control functions for fully automatic operation are provided by the TSC 900 transfer controller. The TSC 900 controller is mounted on the door of the transfer switch enclosure and operating status is shown via 7" color touch-screen graphical display.

SERVICE ENTRANCE ATS

(For U.S. Market Only)

Thomson Power Systems **TS 880 Service Entrance Automatic Transfer Switches** incorporate an isolating mechanism and over current protection on the utility supply thereby removing the need to have a separate, upstream circuit breaker/ disconnect switch. This unique **Service Entrance Rated Automatic Transfer Switch** design is incorporated into a standard sized automatic transfer switch enclosure.

The **Service Entrance Rated ATS** feature is a standard option that can be applied to any **TS 880** model of Thomson Power Systems Transfer Switch.

Standard features of the **Service Entrance Rated Automatic Transfer Switch** include a NEMA 1 rated enclosure, pad-lockable Service Disconnect control switch and status indications.

TS 880 SE Service disconnect operation is simple and ensures a high level of safety for system maintenance personnel. Normal operation and performance of the automatic transfer switch is unaffected by the Service Entrance ATS feature.

TS 880 SE Automatic Transfer Switches are specifically designed and certified to the UL 1008 Standard as well

as complying with NEC and NFPA requirements. **TS 880 SE** Automatic Transfer Switches are for use in Emergency Power System applications such as commercial, industrial, or government institutions that require automatic standby power.

All **TS 880 SE** transfer switch models have been 3 cycle withstand current tested in accordance with UL 1008 and CSA 178 which allow high current ratings and use of nonseries rated upstream protective devices. The **TS 880 SE** Automatic Transfer Switch is rated for the system load and requires upstream over current protection on the generator supply.

The **TS 880 SE** series transfer switches use a type **TSC 900** microprocessor based controller.

TYPICAL SINGLE LINE DIAGRAM

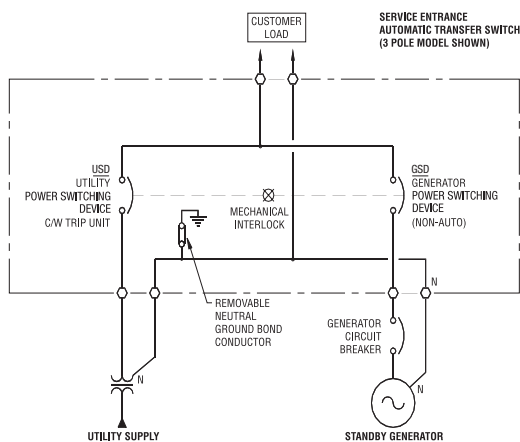

OPERATION MODE

Service Entrance Automatic Transfer Switch	Utility Power Switching Device	Generator Power Switching Device	ATS Load
Operation Mode	Position	Position	
Normal Conditions (Utility Power Supplying Load)	Closed	Open	Energized
Utility Power Failure (Generator Supplying Load)	Open	Closed	Energized
Service Disconnect Mode	Open (Mechanically & electrically interlocked)	Open (Mechanically & electrically interlocked)	De-Energized

CLOSED TRANSITIONS ATS (MOMENTARY)

Thomson Power Systems TS 880 Closed Transition Automatic Transfer Switches employ two electrically interlocked insulated case power switching units and a microprocessor based controller to automatically allow a **Closed Transition** load transfer when both utility and generator sources are available. All Closed Transition transfer sequences ensure both sources of power are in synchronism prior to transfer and load is transferred without power interruption. Automatic control & protection circuits ensure the generator and utility supplies are only in parallel for a maximum of 100 milliseconds to permit an uninterrupted load transfer.

In the event of a utility supply failure, the **TS 880 CT** will automatically revert to an Open Transition load transfer sequence to transfer system load automatically to the generator supply. System load is then automatically re-transferred back to the utility supply utilizing a Closed Transition transfer sequence following restoration of the utility power source to within normal operating limits. All Closed Transition transfer sequences will be inhibited when only one source of power is available. The Closed Transition feature is a standard option that can be applied to TS 880 models of Thomson Power Systems Transfer Switches 800A and above.

TS 880 CT Automatic Transfer Switches are specifically designed and certified to UL 1008 Standards. For use in Emergency Power System applications such as commercial, industrial, or government institutions that require automatic standby power and minimal power interruptions to the load.

All TS 880 CT transfer switch models have been 3 cycle withstand current tested in accordance with UL 1008.

The standard TS 880 CT Automatic Transfer Switch is rated for 100% system load and requires upstream over current protection. The TS 880 CT design allows optional use of integral over current trip elements within the power switching units thus eliminating the need for external, upstream protective devices.

The TS 880 CT series transfer switches use a type TSC 900 microprocessor based controller.



DUAL SOURCE ATS

Thomson Power Systems TS 880 Dual Source Automatic Transfer Switches employ two mechanically interlocked power switching units with a microprocessor based controller to automatically control two sources of power such as dual utility feeders or dual prime operating generator sets. Upon failure of the preferred operating source, the load will automatically be transferred to the alternate source. System load is then automatically re-transferred back to the preferred operating source following restoration of the power source to within normal operating limits. All load transfer sequences are "Open Transition" (i.e. "break-before-make") with adjustable neutral position delay unless the Closed Transition option (CT) is supplied with the transfer switch.

TS 880 DS Automatic Transfer Switches are specifically designed and certified to CSA 178 and UL 1008 Standards.

All **TS 880 DS** transfer switch models have been 3 cycle withstand current tested in accordance with UL 1008 and CSA 178 which allow high current ratings.

The standard **TS 880 DS** Automatic Transfer Switch is rated for 100% system load and requires upstream over current protection. The TS 880 design allows optional use of integral over current trip elements within the power switching units thus eliminating the need for external, upstream protective devices.

The **TS 880 DS** series transfer switches use a type **TSC 900** microprocessor based controller.

BYPASS ISOLATION ATS

Thomson Power Systems TS 880 Bypass/Isolation Automatic Transfer Switches employ a interlocked power switching mechanism that provides an easy and safe procedure for system maintenance personnel to manually isolate and bypass an automatic transfer switch. The Bypass/Isolation switch is manually operated and allows either generator or utility source to be bypassed to maintain power to the load while the automatic transfer switch is tested for maintenance procedures as required. The bypass/isolation procedure allows a fast, simple and reliable method of isolating and bypassing the automatic transfer switch through a “break-before-make” bypass design. The mechanical interlocking mechanism ensures that the utility and generator sources cannot be paralleled under any circumstance and the transfer switch may be bypassed to either source.

Note: Automatic transfer switch units rated 800A to 4000A utilizing insulated case power switching units with a closed transition option may be operated in a “make-before-break” sequence at the operators’ direction.

The **TS 880 Bypass/Isolation Automatic Transfer Switch** is supplied as a single complete assembly with all power conductors provided between the bypass mechanism and the transfer switch. Provisions for all external power cabling for the utility, generator and load conductors are provided for in the bypass/

isolation compartment of the switch. The bypass/isolation switch and transfer switch are mounted in separate barriered compartments.

Transfer switches rated 800A through 4000A using insulated case power switching devices, the bypass isolation mechanism consists of 2 mechanically interlocked power switch devices and draw-out transfer power switching devices with key interlock mechanism. Utilizing independent switching units provides a high degree of reliability and redundancy not available in other switches.

TS 880 Bypass/Isolation Automatic Transfer Switches are specifically designed and certified to UL 1008 and CSA 22.2 No. 178 Safety Standards.

All **TS 880 Bypass/Isolation Automatic Transfer Switch** models have been 3 cycle withstand current tested in accordance with UL 1008 and CSA 22.2 No. 178.

The standard **TS 880 Bypass/Isolation Automatic Transfer Switch** is rated for 100% system load and requires upstream over current protection.

TYPICAL SINGLE LINE DIAGRAM

**800A - 4000A Insulated Case
Bypass/Isolation Automatic Transfer Switch**

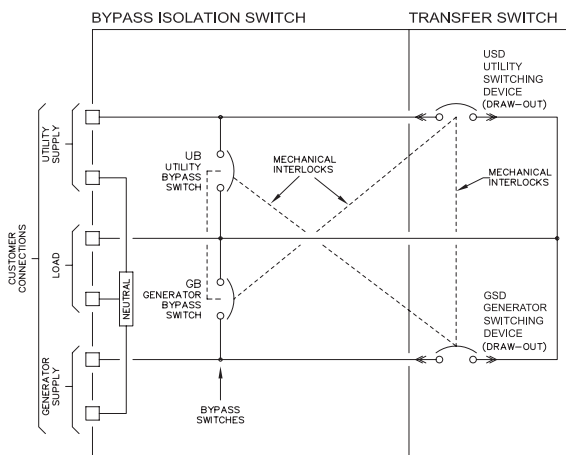

WITHSTAND CURRENT RATINGS (ALL MODELS)

BASIC MODEL	MAXIMUM VOLTAGE	RATED CURRENT (AMPS)	WITHSTAND CURRENT RATING AMPS (RMS) ¹				
			With Upstream Circuit Breaker Protection			With Upstream Fuse Protection	
			@240V	@480V	@600V	@ up to 600v	FUSE TYPE
TS 88xA-0800	600	800	100,000	100,000	85,000	100,000	Consult Factory
TS 88xA-1200	600	1200	100,000	100,000	85,000	100,000	Consult Factory
TS 88xA-1600	600	1600	100,000	100,000	85,000	100,000	Consult Factory
TS 88xA-2000	600	2000	100,000	100,000	85,000	100,000	Consult Factory
TS 88xA-2500	600	2500	100,000	100,000	85,000	100,000	Consult Factory
TS 88xA-3000	600	3000	100,000	100,000	85,000	100,000	Consult Factory
TS 88xA-4000	600	4000	100,000	100,000	85,000	100,000	Consult Factory

ENCLOSURE DIMENSIONS/CABLE TERMINATIONS (ATS only)

BASIC MODEL	DIMENSIONS (Inches) ¹				SHIPPING WEIGHT (LBS)	TERMINAL RATING ²	
	HEIGHT	WIDTH	DEPTH	DEPTH (Drawing Option)		QTY PER PHASE	RANGE 2
TS 88xA- 0800	91.5	36	42	48	1500	3	#2-600 MCM
TS 88xA- 1200	91.5	36	42	48	1500	4	#2-600 MCM
TS 88xA- 1600	91.5	36	42	48	1500	5	#2-600 MCM
TS 88xA- 2000	91.5	36	42	48	1500	6	#2-600 MCM
TS 88xA- 2500	91.5	36	60	60	1800	7	#2-600 MCM
TS 88xA- 3000	91.5	36	60	60	1800	8	#2-600 MCM
TS 88xA- 4000	91.5	48	72	72	2400	11	#2-600 MCM

Optional NEMA 1, 12, 2, 3R & 4X (up to 600A) class enclosures available — consult Thomson Power Systems.

¹ Enclosure dimensions are for reference. (DO NOT USE FOR CONSTRUCTION).

² All cable connections suitable for copper or aluminum.

³ Enclosure depth shown has cable entry/exit location restrictions. Contact Factory for further detailed information.

* Enclosures painted ASA #61grey.

ENCLOSURE DIMENSIONS/CABLE TERMINATIONS

(ATS with Bypass Switch)

BASIC MODEL	NEMA 1 DIMENSIONS (INCHES) ¹						SHIPPING WEIGHT		TERMINAL RATING	
	HEIGHT		WIDTH		DEPTH ³		(LBS)		QTY PER PHASE	RANGE ²
	3 POLE	4 POLE	3 POLE	4 POLE	3 POLE	4 POLE	3 POLE	4 POLE		
TS 88XB- 0800	92	92	72	72	66	66	3000	3100	3	#2-600MCM
TS 88XB- 1200	92	92	72	72	66	66	3000	3100	4	#2-600MCM
TS 88XB- 1600	92	92	72	72	66	66	3000	3100	5	#2-600MCM
TS 88XB- 2000	92	92	72	72	66	66	3000	3100	6	#2-600MCM
TS 88XB- 2500	92	92	72	72	66	66	3600	3750	7	#2-600MCM
TS 88XB- 3000	92	92	72	72	66	66	3600	3750	8	#2-600MCM
TS 88XB- 4000	92	92	96	96	90	90	4800	5000	11	#2-600MCM

1 Enclosure dimensions are for reference. (DO NOT USE FOR CONSTRUCTION).

2 All cable connections suitable for copper or aluminum.

3 Enclosure depth shown has cable entry/exit location restrictions. Contact Factory for further detailed information.

* Enclosures painted ASA #61grey.

STANDARD FEATURES

- 7" color touch screen graphical display for monitoring 3 Phase Utility/Generator voltage, system frequency and timer countdown operation
- Front Panel Programming using touchscreen graphical display with password security
- Load on Utility & Load on Generator indication
- Utility & Generator Source available indication
- 3 Phase Voltage sensing on Utility & Generator Sources
- Generator AC frequency sensing
- Utility under voltage control setpoint 70 - 95% (adjustable)
- Generator under voltage control setpoint 70 - 95% (adjustable)
- Generator under frequency control setpoint 70 - 90% (adjustable)
- Engine warm-up timer 0-60 sec. (adjustable)
- Utility return timer 0-30 min. (adjustable)
- Engine start timer 0-60 sec. (adjustable)
- Engine cooldown timer 0-30 min. (adjustable)
- Neutral position delay timer 0-60 sec. (adjustable)
- Load Disconnect Contact (LDC) for pre/post transfer control to signal external building systems such as elevators during transfer operations
- Programmable Generator Exercise Timer (EXT) with easy to use event, Calendar Based, On-load or Off-load Programmability
- Real-time clock c/w battery back-up & daylight-savings programming
- Data logging including total transfers to generator, total utility power failures, load on utility hours, load on generator hours and utility or generator voltage/frequency data at time of fault
- Eight user Programmable Output Contacts rated 2A, 120/240V resistive, Form C. Each output contact is user programmable to 20 different functions including: Load on Utility, Load on Gen, Load Disconnect Contact (LDC), Fail to Transfer (FTT), Utility Power Available (UPA), Generator Power Available (GPA), Utility Power Fail, Engine start, ATS Not in Auto, and ATS in Auto. The Transfer Switch is pre-programmed with the following outputs enabled:
 - Load on Utility
 - Load on Gen
 - Load Disconnect Contact (LDC)
 - Fail to Transfer (FTT)
 - ATS Not in Auto
- Local utility power fail simulation test
- Remote utility power fail simulation test pushbutton input



- Local plant exercise initiate pushbutton control
- Engine start contact (7A, 120/240VAC resistive max.)
- Transfer fail/forced transfer logic
- Automatic force transfer to alternate supply should load voltage become de-energized
- 50 or 60Hz capable (115V control power)
- Remote Load Test/Peak Shave Input
- NEMA 1 Enclosure
- Solid Neutral on 4 wire Systems
- Auto Configuring System Voltage Type (3 wire delta or 4 wire Wye capable without additional sensing transformers)
- ATS Load Bus Power Metering Capability (Amp, Volt, Freq, kW, kVA, PF)*
- Under/Over Frequency Protection- Utility and Generator Sources
- 3 Phase Over Voltage Protection - Utility and Generator Sources
- Phase Sequence and Phase Rotation Protection between Utility and Generator Sources
- Voltage Phase Loss/Unbalance Protection
- Programmable Inputs (Quantity 16 Digital Input-voltage free input)
- RS232 Modbus Remote Communication Port (Modbus Serial RTU) via GHC
- Optional Ethernet Modbus™ Remote Communication Port (Modbus™ TCP) via GHC
- USB Communication Port (Quantity 3 via GHC)
- Serviceable Plug-in Connectors
- Event Logging (Time/Date Stamping)

* Power Metering requires Current Transformer Option Kit

TS 880 ORDERING INFORMATION

When placing an order, specify the following 21 digit ATS MODEL CODE as per the features and applications described below.

1	2	3	4	5	6	7	8	9	10	11	12	13	14	15	16	17	18	19	20	21
T	S		8	8																

1-3. SERIES

TS – TRANSFER SWITCH

4 & 5. MODEL

88 – 880 SWITCH

6. POLES

3 – 3 POLE

4 – 4 POLE

7. CONFIGURATION TYPE

A – ATS

B – BYPASS/ISOLATION ATS

X – SPECIAL

8-11. AMPERAGE

0800

1000

1200

1600

2000

2500

3000

4000

12. APPLICATION

A – STANDARD

B – SERVICE ENTRANCE

C – DUAL SOURCE

D – DUAL SOURCE (Master/Slave Config.)

X – SPECIAL

13. OPERATION TYPE

1 – OPEN TRANSITION

2 – MANUAL ELEC. OP.

3 – CLOSED TRANSITION (MOMENTARY)

4 – CLOSED TRANSITION (SOFT LOAD)

X – SPECIAL

14. SAFETY STANDARD

A – UL 1008 (Service Entrance)

C – UL 1008 / CSA 178

X – NOT APPLICABLE

15. VOLTAGE

3ø 4 WIRE (GROUNDED NEUTRAL)

E – 120/208¹

F – 127/220

G – 120/240¹ (DELTA)

H – 220/380²

15. VOLTAGE (CONT'D)

S – 230/400²

J – 240/416

K – 254/440

M – 277/480¹

N – 347/600¹

3ø 3 WIRE

P – 208

Q – 220

R – 240

U – 416

V – 480

W – 600

X – SPECIAL

16. CONTROLLER

5 – TSC 900 c/w GHC GRAPHIC DISPLAY

7 – NONE (MANUAL)

17. ENCLOSURE TYPE

A – NEMA 1, ASA #61 GREY

B – NEMA 2, ASA #61 GREY

C – NEMA 12, ASA #61 GREY

D – NEMA 3R SD, ASA #61 GREY

E – NEMA 3R DD, ASA #61 GREY

F – NEMA 3RX/4X DD (304 STAINLESS STEEL)

G – NONE (OPEN STYLE)

H – NEMA 4X SD (304 STAINLESS STEEL)

K – NEMA 4X SD (316 STAINLESS STEEL)

L – NEMA 3RX/4X DD (316 STAINLESS STEEL)

X – SPECIAL

18. UTILITY SWITCHING DEVICE

Q – INSULATED CASE, FIX-MOUNT SWITCH (800A-4000A)

R – INSULATED CASE, FIX-MOUNT SWITCH C/W ELECTRONIC TRIP (800-4000A)

T – INSULATED CASE, FIX-MOUNT SWITCH C/W ELECTRONIC & GF TRIP (800-4000A)

U – INSULATED CASE, DRAW-OUT SWITCH (800-4000A)

V – INSULATED CASE, DRAW-OUT

SWITCH C/W ELECTRONIC TRIP (800-4000A)

W – INSULATED CASE, DRAW-OUT SWITCH C/W ELECTRONIC & GF TRIP (800-4000A)

X – SPECIAL

19. GENERATOR SWITCHING DEVICE

Q – INSULATED CASE, FIX-MOUNT SWITCH (800A-4000A)

R – INSULATED CASE, FIX-MOUNT SWITCH C/W ELECTRONIC TRIP (800-4000A)

T – INSULATED CASE, FIX-MOUNT SWITCH C/W ELECTRONIC & GF TRIP (800-4000A)

U – INSULATED CASE, DRAW-OUT SWITCH (800-4000A)

V – INSULATED CASE, DRAW-OUT SWITCH C/W ELECTRONIC TRIP (800-4000A)

W – INSULATED CASE, DRAW-OUT SWITCH C/W ELECTRONIC & GF TRIP (800-4000A)

X – SPECIAL

20. POWER CONNECTIONS

A – STANDARD

X – SPECIAL

21. ATS CONNECTION CONFIGURATION ³

E – ALTERNATE E (800-4000A)

F – ALTERNATE F (800-4000A)

G – ALTERNATE G (800-4000A)

X – SPECIAL

NOTES:

¹ MULTI-VOLTAGE CAPABLE

² FOR 50HZ APPLICATION

³ FOR BYPASS SWITCH APPLICATIONS REFER TO FACTORY.

OPTIONAL FEATURES

(Specify separately from ATS MODEL CODE when ordering)

FEATURED CODE:

FEATURED DESCRIPTION:

AUXILIARIES:

AUX-BG	Generator Bypass Auxiliary Contact
AUX-BU	Utility Bypass Auxiliary Contact
KOTS	Key Operated Test Switch- Auto/Off/Engine Start/Test
PPR-10	Programmable Power Relay Includes 10A Form C Contact Wired to Terminal Block (Up to Qty 3)
TS-STG	24Vdc or 120VAC Shunt Trip Generator Switch (external power source required)
TS-STU	24Vdc or 120VAC Shunt Trip Utility Switch (external power source required)

COMMUNICATION:

EAP1601	Transfer to Emergency Annunciator, Alarm Horn & Silence Pushbutton
EMB-TCP/IP	Ethernet Modbus™ Remote Communication Port (Modbus™ TCP) via GHC
RS485A	RS 232 to RS 485 Remote Communication Adapter
WF-USB	WIFI USB Stick

ENCLOSURE:

GHC-SS	Sunshade for GHC Screen
LCK	Enclosure Lockable Door (Single point T-Handle lock)
TS-H1	Enclosure Strip Heater c/w Thermostat (120VAC external power source required)
TS-H2	Enclosure Strip Heater c/w Thermostat (internally powered from ATS load)

FUNCTION:

DS	Dual Source Control Package Dual Utility or Generator
DP	Master/Slave Configuration
MTS	Manually Initiated Electrically Operated Transfer Switch c/w Source Selector Switch, Position Indicating Lights, Source Available Lights
TCP	Transfer Switch Connection Plate for Generator Supply
TS-SS	Internal Multi-Voltage Selector Switch (208V/240V/480V)

METERING:

APM	Advanced Power Metering Software (Amps, V, F, kW, kVA, PF, KW/H, Trending). **Requires CT Kit
LPM	Transfer Switch Load Power Metering CT Kit (Amp, Volt, Freq, kW, kVA, PF) **Requires CT Kit
CTK	Current Transformer Kit
MUP	Multifunction Utility Protective Relay – Basler IPS100 (Protection Functions 27, 32, 47, 50/51, 67, 81O/U (Note: May be required by local utility for Soft Load CT applications or even Momentary CT applications. Consult factory for other makes and models.)

POWER:

24DCC	24 Volt DC-DC Converter, Regulated
SPD	Surge Protection Device

OTHER:

3YR	Additional 12 Month Parts & Labour Warranty
5YR	Additional 36 Month Parts & Labour Warranty

NOTE: Specifications subject to change without notice.



NOTES:

marathon[™]
Thomson Power Systems



9087A - 198th Street
Langley, BC Canada V1M 3B1
PH: 604-888-0110
FAX: 604-888-3381

www.thomsonps.com



A Regal Brand

REGAL

www.regalbeloit.com